

LCD Monitor

Operating Instructions

LMD-2451W

Owner's Record

The model and serial numbers are located at the rear. Record these numbers in the spaces provided below. Refer to these numbers whenever you call upon your Sony dealer regarding this product.

Model No. _____
Serial No. _____

WARNING

To reduce the risk of fire or electric shock, do not expose this apparatus to rain or moisture.

To avoid electrical shock, do not open the cabinet. Refer servicing to qualified personnel only.

WARNING

THIS APPARATUS MUST BE EARTHED.

WARNING

When installing the unit, incorporate a readily accessible disconnect device in the fixed wiring, or connect the power plug to an easily accessible socket-outlet near the unit. If a fault should occur during operation of the unit, operate the disconnect device to switch the power supply off, or disconnect the power plug.

Attention-when the product is installed in Rack:

1.Prevention against overloading of branch circuit

When this product is installed in a rack and is supplied power from an outlet on the rack, please make sure that the rack does not overload the supply circuit.

2.Providing protective earth

When this product is installed in a rack and is supplied power from an outlet on the rack, please confirm that the outlet is provided with a suitable protective earth connection.

3.Internal air ambient temperature of the rack

When this product is installed in a rack, please make sure that the internal air ambient temperature of the rack is within the specified limit of this product.

4.Prevention against achieving hazardous condition due to uneven mechanical loading

When this product is installed in a rack, please make sure that the rack does not achieve hazardous condition due to uneven mechanical loading.

5.Install the equipment while taking the operating temperature of the equipment into consideration

For the operating temperature of the equipment, refer to the specifications of the Operation Manual.

6.When performing the installation, keep the following space away from walls in order to obtain proper exhaust and radiation of heat.

Lower , Upper : 4.4 cm (1 3/4 inches) or more

For kundene i Norge

Dette utstyret kan kobles til et IT-strømfordelingssystem.

For the customers in the U.S.A.

This equipment has been tested and found to comply with the limits for a Class A digital device, pursuant to Part 15 of the FCC Rules. These limits are designed to provide reasonable protection against harmful interference when the equipment is operated in a commercial environment. This equipment generates, uses, and can radiate radio frequency energy and, if not installed and used in accordance with the instruction manual, may cause harmful interference to radio communications. Operation of this equipment in a residential area is likely to cause harmful interference in which case the user will be required to correct the interference at his own expense.

You are cautioned that any changes or modifications not expressly approved in this manual could void your authority to operate this equipment.

All interface cables used to connect peripherals must be shielded in order to comply with the limits for a digital device pursuant to Subpart B of Part 15 of FCC Rules.

This device complies with Part 15 of the FCC Rules. Operation is subject to the following two conditions: (1) this device may not cause harmful interference, and (2) this device must accept any interference received, including interference that may cause undesired operation.

WARNING:

Using this unit at a voltage other than 120 V may require the use of a different line cord or attachment plug, or both. To reduce the risk of fire or electric shock, refer servicing to qualified service personnel.

For the customers in Canada

This Class A digital apparatus complies with Canadian ICES-003.

For the customers in Europe

This product with the CE marking complies with both the EMC Directive and the Low Voltage Directive issued by the Commission of the European Community.

Compliance with these directives implies conformity to the following European standards:

- EN60950-1 : Product Safety
- EN55103-1 : Electromagnetic Interference (Emission)
- EN55103-2 : Electromagnetic Susceptibility (Immunity)

This product is intended for use in the following Electromagnetic Environments:

E1 (residential), E2 (commercial and light industrial), E3 (urban outdoors), E4 (controlled EMC environment, ex. TV studio).

For the customers in Europe

The manufacturer of this product is Sony Corporation, 1-7-1 Konan, Minato-ku, Tokyo, Japan.

The Authorized Representative for EMC and product safety is Sony Deutschland GmbH, Hedelfinger Strasse 61, 70327 Stuttgart, Germany. For any service or guarantee matters please refer to the addresses given in separate service or guarantee documents.

For the customers in the USA

Lamp in this product contains mercury. Disposal of these materials may be regulated due to environmental considerations. For disposal or recycling information, please contact your local authorities or the Electronic Industries Alliance (www.eiae.org).

Table of Contents

Precaution	5
On Safety	5
On Installation	5
Handling the LCD Screen	5
About the Fluorescent Tube	5
On Cleaning	5
On Repacking	6
On Mounting on a Rack	6
On Fan Error	6
Features	6
Location and Function of Parts and Controls	8
Front Panel	8
Input Signals and Adjustable/Setting Items	10
Rear/Bottom Panel	11
Adjusting the Height of the Stand	13
Connecting the AC Power Cord	14
Installing the Input Adaptor	14
Selecting the Default Settings	15
Selecting the Menu Language	16
Using the Menu	17
Adjustment Using the Menus	19
Items	19
Adjusting and Changing the Settings	20
STATUS menu.....	20
COLOR TEMP/SPACE menu.....	20
USER CONTROL menu.....	21
USER CONFIG menu.....	23
REMOTE menu	29
KEY INHIBIT menu.....	30
Troubleshooting	31
Specifications	32
Dimensions	36

Precaution

On Safety

- Operate the unit only with a power source as specified in the “Specifications” section.
- A nameplate indicating operating voltage, etc., is located on the rear panel.
- Should any solid object or liquid fall into the cabinet, unplug the unit and have it checked by qualified personnel before operating it any further.
- Do not drop or place heavy objects on the power cord. If the power cord is damaged, turn off the power immediately. It is dangerous to use the unit with a damaged power cord.
- Unplug the unit from the wall outlet if it is not to be used for several days or more.
- Disconnect the power cord from the AC outlet by grasping the plug, not by pulling the cord.
- The socket-outlet shall be installed near the equipment and shall be easily accessible.

On Installation

- Allow adequate air circulation to prevent internal heat build-up.
Do not place the unit on surfaces (rugs, blankets, etc.) or near materials (curtains, draperies) that may block the ventilation holes.
- Do not install the unit in a location near heat sources such as radiators or air ducts, or in a place subject to direct sunlight, excessive dust, mechanical vibration or shock.

Handling the LCD Screen

- The LCD panel fitted to this unit is manufactured with high precision technology, giving a functioning pixel ratio of at least 99.99%. Thus a very small proportion of pixels may be “stuck”, either always off (black), always on (red, green, or blue), or flashing. In addition, over a long period of use, because of the physical characteristics of the liquid crystal display, such “stuck” pixels may appear spontaneously. These problems are not a malfunction.
- Do not leave the LCD screen facing the sun as it can damage the LCD screen. Take care when you place the unit by a window.
- Do not push or scratch the LCD monitor’s screen. Do not place a heavy object on the LCD monitor’s screen. This may cause the screen to lose uniformity.

- If the unit is used in a cold place, horizontal lines or a residual image may appear on the screen. This is not a malfunction. When the monitor becomes warm, the screen returns to normal.
- If a fixed picture such as a frame of a divided picture or time code, or a still picture is displayed for a long time, an image may remain on the screen and be superimposed as a ghosting image.
- The screen and the cabinet become warm during operation. This is not a malfunction.

About the Fluorescent Tube

A specially designed fluorescent tube is installed as the lighting apparatus for this unit. If the LCD screen becomes dark, unstable or does not turn on, consult your Sony dealer.

On Cleaning

Before cleaning

Be sure to disconnect the AC power cord from the AC outlet.

On cleaning the monitor screen

The monitor screen surface is especially treated to reduce reflection of light.

As incorrect maintenance may impair the performance of the monitor, take care with respect to the following:

- Wipe the screen gently with a soft cloth such as a cleaning cloth or glass cleaning cloth.
- Stubborn stains may be removed with a soft cloth such as a cleaning cloth or glass cleaning cloth lightly dampened with water.
- Never use solvent such as alcohol, benzene or thinner, or acid, alkaline or abrasive detergent, or chemical cleaning cloth, as they will damage the screen surface.

On cleaning the cabinet

- Clean the cabinet gently with a soft dry cloth. Stubborn stains may be removed with a cloth lightly dampened with mild detergent solution, followed by wiping with a soft dry cloth.
- Use of alcohol, benzene, thinner or insecticide may damage the finish of the cabinet or remove the indications on the cabinet. Do not use these chemicals.
- If you rub on the cabinet with a stained cloth, the cabinet may be scratched.
- If the cabinet is in contact with a rubber or vinyl resin product for a long period of time, the finish of the cabinet may deteriorate or the coating may come off.

On Repacking

Do not throw away the carton and packing materials. They make an ideal container which to transport the unit.

On Mounting on a Rack

Leave 1U space empty above and below the monitor to ensure adequate air circulation or install a fan to maintain the monitor's performance.

If you have any questions about this unit, contact an authorized Sony dealer.

On Fan Error

The fan for cooling the unit is built in. When the fan stops and the RETURN button on the front panel blinks for fan error indication, turn off the power and contact an authorized Sony dealer.

Features

The LMD-2451W (24-type) is a multiple format LCD monitor for broadcast or business use featuring a precise image and high performance. It supports both digital or analog main broadcast signal and PC input. It is also equipped with functions to adjust for various objects or use.

High brightness LCD panel

Because of precise image, wide viewing angle technology and high speed response, real color image can be reproduced.

Multi-format

The monitor supports the video, Y/C, RGB, component, SDI (3G/HD/SD, when the optional input adaptor is used.) signals and NTSC/PAL color systems. SDI supports not only HD-SDI and SD-SDI, but also 3G-SDI, which transmits twice as much data as HD-SDI with a Single-link. HD15 (analog) and DVI-D (digital) connectors are equipped for the PC input.

For more information, refer to "Available signal formats" on page 33.

Expandable input capability

The input connector configuration can be easily modified by installing the optional input adaptor into the optional input slot on the bottom of the monitor. Up to two adaptors can be installed.

For more information, refer to "Available signal formats" on page 33.

External remote function

The input signal is selected or various items are adjusted by use of the serial (Ethernet) remote function. Up to 32 monitors and control units (max. 4) can be connected by the Ethernet (10BASE-T/100BASE-TX) connection and controlled remotely on the network. You can control individual monitors or monitor groups simply by entering the monitor ID or group ID number. You can also execute the same operation on all connected monitors, or put all connected monitors into the same setup and adjustment state.

For more information, refer to SERIAL REMOTE of REMOTE menu on page 29.

Refer to the Operation Manual of the BKM-15R Monitor Control Unit.

Monitor stand with tilt function

A monitor stand with tilt function is equipped. You can select the height of the monitor by adjusting the height, when it is used on a desk.

For more information, refer to “Adjusting the Height of the Stand” on page 13.

Rack mount

The monitor supports the VESA (100 × 100) standard.

Two-display

Two kinds of input signals are put on the monitor.

For more information, refer to *MULTI DISPLAY* of “MULTI DISPLAY SETTING” on page 25.

Input signal waveform and audio level display

The waveform of the input signal or the audio level (embedded audio only) is displayed as the sub display.

For more information, refer to *SUB INPUT SELECT* and waveform of “MULTI DISPLAY SETTING” on page 25.

Closed caption

The closed caption conforming to the EIA608 standard is displayed.

The EIA/CEA-608 and EIA/CEA-708 standard closed caption signals superimposed on an SDI signal are displayed by installing the optional input adaptor.

Auto chroma/phase function

The chroma and phase of the decoder are automatically adjusted with the auto chroma/phase function.

Blue only mode

In the blue only mode, a monochrome display is obtained with all three of the R/G/B picture elements driven with a blue signal. This mode is convenient for chroma and phase adjustments and monitoring of VCR noise.

H/V delay mode

The horizontal and vertical sync signals can be monitored simultaneously.

Select marker/scan display

Various items for broadcast use can be displayed. The center marker, safe area marker, aspect marker or display size (scan), etc are displayed by selecting according to use.

For more information, refer to “MARKER SETTING” on page 25 and *SCAN* of “SYSTEM SETTING” on page 23.

APA (Auto Pixel Alignment) function

For the signal input to the HD15 input connector, you can adjust the picture to the appropriate size simply by pressing the button assigned as the APA function.

Select color temperature mode

You can select the color temperature from among two (9300 K, 6500 K) settings.

Color space function

You can select one from among three color space settings (SMPTE-C/EBU/ITU-R BT.709).

On-screen menus

You can set the appropriate settings according to the connected system by using the on-screen menus.

Select language display

You can select from seven display languages, English, French, German, Spanish, Italian, Japanese and Chinese.

Key inhibit function

You can inhibit a key function to prevent missing an operation.

Location and Function of Parts and Controls

Front Panel

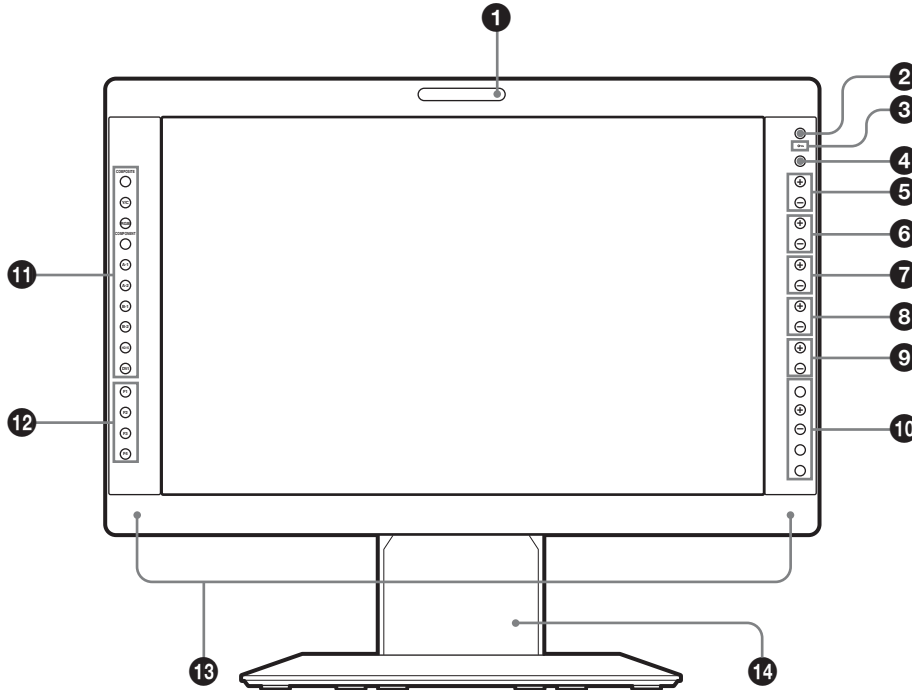

1 Tally lamp

You can check the status of the monitor by the color of the tally lamp.
The tally lamp lights in red, green or amber according to the setting of PARALLEL REMOTE in the REMOTE menu.

2 (standby) switch and indicator

When you press the switch to turn on the power in standby mode (the  switch on the rear panel is turned on), the indicator lights in green.
When you press this switch again, the monitor is set in standby mode and the indicator lights in red.

3 (key inhibit) indicator

Lights in red when the key inhibit is set to ON.

4 CONTROL button

Press to display the buttons on the front panel. Press again to clear the display.

5 VOLUME buttons

Press the + button to increase the volume or the – button to decrease it.

6 CONTRAST buttons

Adjusts the picture contrast.
Press the + button to make the contrast higher or the – button to make it lower.

7 PHASE buttons

Adjusts color tones.
Press the + button to make the skin tones greenish or the – button to make them purplish.

8 CHROMA buttons

Adjusts the color intensity.
Press the + button to increase the color intensity or the – button to decrease it.

9 BRIGHT (brightness) buttons

Adjusts the picture brightness.
Press the + button to increase the brightness or the – button to decrease it.

10 Menu operation buttons

Displays or sets the on-screen menu.

MENU button

Press to display the on-screen menu.
Press again to clear the menu.

+/- buttons

Press to select the items and setting values.

ENTER button

Press to confirm a selected item on the menu.

When the menu is not displayed and the button is pressed, the distinguished signal format is displayed.

RETURN button

When the menu is displayed and the button is pressed, the value of an item is reset to the previous value.

When the menu is not displayed and the button is pressed, the function selected in FUNCTION BUTTON SETTING of the USER CONFIG menu is displayed on the side of the F1 to F4 button. Also, when the fan stops, this button blinks.

11 Input select buttons

Press to monitor the signal input to each connector.

A-1, A-2, B-1 and B-2 buttons are used when an optional input adaptor has been installed in the option slot.

COMPOSITE button: to monitor the signal through the COMPOSITE IN connector

Y/C button: to monitor the signal through the Y/C IN connector

RGB button: to monitor the RGB signal through the connectors for the R/G/B signal input

COMPONENT button: to monitor the component signal through the connectors for Y/PB/PR signal input

A-1 button: to monitor the signal from connector **1** (the connectors for the R/G/B signal input in BKM-229X) of the input adaptor installed to the option slot
A

A-2 button: to monitor the signal from connector **2** (the connectors for Y/PB/PR signal input in BKM-229X) of the input adaptor installed to the option slot
A

B-1 button: to monitor the signal from connector **1** (the connectors for the R/G/B signal input in BKM-229X) of the input adaptor installed to the option slot
B

B-2 button: to monitor the signal from connector **2** (the connectors for Y/PB/PR signal input in BKM-229X) of the input adaptor installed to the option slot
B

HD15 button: to monitor the signal through the HD15 input connector

DVI button: to monitor the signal through the DVI-D input connector

12 Function buttons

You can turn the assigned function on or off.

The factory setting is as follows;

F1 button: EXT SYNC

F2 button: SCAN

F3 button: ASPECT

F4 button: H/V DELAY

You can assign the function from among SCAN, ASPECT, EXT SYNC, BLUE ONLY, MONO,

MARKER, H/V DELAY, MULTI DISPLAY, CLOSED CAPTION and APA in FUNCTION BUTTON SETTING of the USER CONFIG menu (see page 26).

For details of the function assigned to the function button, see page 26.

13 Speakers

The audio signal which is selected by the input select button is output.

When BKM-220D/243HS/244CC/250TG is not installed, the audio signal which is selected in INPUT SELECT of the USER CONFIG menu is output (see page 28).

When BKM-220D/243HS/244CC/250TG is installed, the audio signal of the channel which is selected in OPTION AUDIO SETTING of the USER CONFIG menu is output (see page 28).

The audio signals from the speakers are output from the AUDIO L/R OUT connector on the rear (see page 12).

14 Stand

You can adjust the height of the monitor (see page 13).

Input Signals and Adjustable/Setting Items

Item	Input signal											
	Video* ³ , Y/C* ³	B & W* ³	Component* ⁴		RGB* ⁴		SDI			Computer		
			SD	HD	SD	HD	SD* ⁵	HD* ⁶	3G* ¹¹	DVI	HD15	
CONTRAST* ¹	○	○	○	○	○	○	○	○	○	○	○	○
BRIGHT* ¹	○	○	○	○	○	○	○	○	○	○	○	○
CHROMA* ¹	○	×	○	○	×	×	○	○	○	○	○	○
PHASE* ¹	○ (NTSC)	×	×	×	×	×	×	×	×	○	○	○
APERTURE	○	○	○	○	○	○	○	○	○	○	○	○
COLOR TEMP	○	○	○	○	○	○	○	○	○	○	○	○
COLOR SPACE	○	○	○	○	○	○	○	○	○	○	○	○
AUTO CHROMA/ PHASE	○	×	○	○	×	×	×	×	×	×	×	×
ACC	○	×	×	×	×	×	×	×	×	×	×	×
CTI	○	×	○	×	×	×	×	×	×	×	×	×
V SHARPNESS	○	○	○	×	○	×	○	×	×	×	×	×
MATRIX* ²	×	×	○	×	×	×	×	×	×	×	×	×
COMPONENT LEVEL	×	×	○ (480/60I)	×	×	×	×	×	×	×	×	×
NTSC SETUP	○ (NTSC)	○ (480/60I)	×	×	×	×	×	×	×	×	×	×
SCAN	○	○	○	○	○	○	○	○	○	○	×	×
ASPECT	○	○	○	×	○	×	○	×	×	×	×	×
MARKER	○	○	○	○	○	○	○	○	○	○	×	×
BLUE ONLY	○	×	○	○	○	○	○	○	○	○	×	×
MONO	○	×	○	○	×	×	○	○	○	○	×	×
H/V DELAY	○	○	○	○	○	○	○	○	○	○	×	×
APA	×	×	×	×	×	×	×	×	×	×	×	○
SIZE	×	×	×	×	×	×	×	×	×	×	×	○
SHIFT	○	○	○	○	○	○	○	○	○	○	×	○
PITCH	×	×	×	×	×	×	×	×	×	×	×	○
DOT PHASE	×	×	×	×	×	×	×	×	×	×	×	○
POWER SAVING	○	○	○	○	○	○	○	○	○	○	○	○
I/P MODE* ⁷	○	○	○	○	○	○	○	○	○	×	×	×
MULTI DISPLAY	○	○	○	○	○	○	○	○	○	○	○* ⁹	○* ⁹
CLOSED CAPTION	○* ⁸	○* ⁸	×	×	×	×	○* ¹⁰	○* ¹⁰	×	×	×	×

○ : Adjustable/can be set
 × : Not adjustable/cannot be set

- *1 Adjustment of SUB CONTROL is the same.
- *2 When a component signal (480/60I or 480/60P) is input and the COMPONENT LEVEL is set to SMPTE, this can be switchable.
- *3 When a BKM-227W is installed, the number of the input connector is increased.

- *4 When a BKM-229X is installed, the number of the input connector is increased.
- *5 When a BKM-220D, BKM-243HS or BKM-244CC is installed, the signal is input.
- *6 When a BKM-243HS or BKM-244CC is installed, the signal is input.
- *7 Only the interlace signal is input.
- *8 Only when an NTSC signal is input and no markers are displayed. Not displayed when the multi display is enabled.

*9 The signal can only be selected in the main display (see “SUB INPUT SELECT” on page 26).

*10 When a BKM-244CC is installed, closed captions are displayed.

*11 When a BKM-250TG is installed, the signal is input.

Rear/Bottom Panel

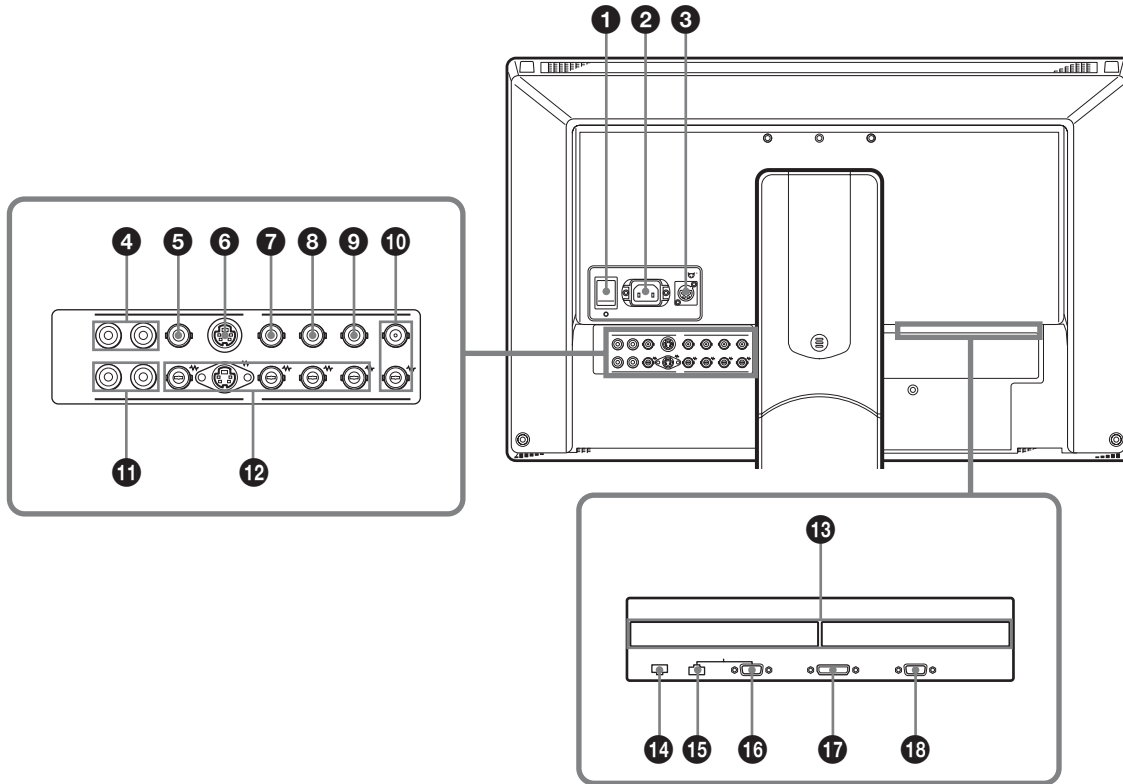

1 ○/I (power) switch

The power is turned on or off.
The monitor is turned on by pressing side I.

2 AC IN socket

Connect the supplied AC power cord.

3 DC 24V IN connector

Plug the DC 24V power supply to this connector to provide power to the monitor.

4 AUDIO L/R IN connectors (phono jack)

Connect to the audio outputs of a VCR or to an audio mixer.

5 COMPOSITE IN connector (BNC)

Input connector for composite signals.

6 Y/C IN connector (4-pin mini-DIN)

Input connector for Y/C signals.

7 G/Y IN connector (BNC)

Input connector for G of RGB signals and component Y (luminance) signals.

8 B/P_B IN connector (BNC)

Input connector for B of RGB signals and P_B (blue color difference) of component signals.

9 R/P_R IN connector (BNC)

Input connector for R of RGB signals and P_R (red color difference) of component signals.

10 EXT SYNC IN/OUT (external sync) connectors (BNC)

To use the external sync signal, press the function button that EXT SYNC is assigned (F1 button at the factory setting).

IN connector

When this unit operates on an external sync signal, connect the reference signal from a sync generator to this connector.

Note

When inputting a video signal with the jitters, etc. the picture may be disturbed. We recommend using the TBC (time base corrector).

OUT connector

Loop-through output of the IN connector. Connect to the external sync input of video equipment to be synchronized with this unit.

When the cable is connected to this connector, the 75-ohm termination of the input is automatically released, and the signal input to the IN connector is output from this connector.

11 AUDIO L/R OUT connectors (phono jack)

Outputs the audio signal which is selected by the input select button on the front panel.

When BKM-220D/243HS/244CC/250TG is not installed, output the audio signal which is selected in INPUT SELECT of the USER CONFIG menu (see page 28).

When BKM-220D/243HS/244CC/250TG is installed, output the audio signal of the channel which is selected in OPTION AUDIO SETTING of the USER CONFIG menu (see page 28).

The audio signal from this connector is monitored on the front speakers (see page 9).

12 Loop-through output connectors

Outputs the signals input to the input connectors (5 to 9). Connect to the analog input (composite, Y/C, analog component or analog RGB) of equipment, according to the input signal.

13 Optional input slot

An optional input adaptor can be installed according to your system configuration (see page 14).

The left side slot is A and the right side slot B.

Press the A-1, A-2, B-1 or B-2 button to select the signal.

14 PARALLEL REMOTE connector (modular connector, 8-pin)

Forms a parallel switch and controls the monitor externally.

For details on the pin assignment and factory setting function assigned to each pin, see page 33.

CAUTION

For safety, do not connect the connector for peripheral device wiring that might have excessive voltage to this port. Follow the instructions for this port.

15 SERIAL REMOTE connector (RJ-45)

Connect to the network or Sony BKM-15R Monitor Control Unit by using a 10BASE-T/100BASE-TX LAN cable (shielded type, optional).

For details, refer to the Interface Manual for Programmers (saved in the supplied CD-ROM, Japanese and English only.)

CAUTION

- When you connect the optional LAN cable of the unit to peripheral device, use a shielded-type cable to prevent malfunction due to radiation noise.
- For safety, do not connect the connector for peripheral device wiring that might have excessive voltage to this port. Follow the instructions for this port.
- The connection speed may be affected by the network system. This unit does not guarantee the communication speed or quality of 10BASE-T/100BASE-TX.

16 SERIAL REMOTE RS-232C connector (D-sub 9-pin, female)

Connect to the RS-232C control connector on external equipment connected to the monitor. The monitor can be operated according to control commands sent from external equipment connected to it.

For details on the pin assignment and factory setting function assigned to each pin, see page 33.

For details, refer to the Interface Manual for Programmers (saved in the supplied CD-ROM, Japanese and English only.)

17 DVI-D input connector (DVI-D)

Inputs DVI Rev.1.0 applicable digital RGB signal.

To view the signals of the SXGA and higher resolution when the DVI input is selected, use the cable within 3 m (118 1/8 inches) in length.

18 HD15 input connector (D-sub 15 pin, female)

Inputs an analog RGB video signal (0.7 Vp-p, positive polarity) and sync signal.

The Plug & Play function corresponds to DDC2B.

Adjusting the Height of the Stand

You can adjust the height of the monitor in three levels by changing the position of the stand attachment bracket and the arm attachment position. Depending on the height, you can install the input adaptor with the stand attached to the monitor.

A and B in the following list indicate the screw holes shown in the illustrations in steps 2 and 4.

Height of the monitor

Unit: mm (inches)

Position of the stand attachment bracket	A	A	B	B
Arm attachment position	B	A	B	A
LMD-2451W	— ³⁾	430.5 (17)	471.6 ¹⁾ (18 5/8)	497.9 ^{1), 2)} (19 5/8)

¹⁾ You can install the input adaptor with the stand attached to the monitor.

²⁾ Default setting

³⁾ You cannot attach the stand in combinations of these positions.

- 1 Remove the stand attachment bracket (see “To remove the stand attachment bracket”).
- 2 Attach the stand attachment bracket to the A or B screw holes.

The bracket is attached to the B holes at the factory.

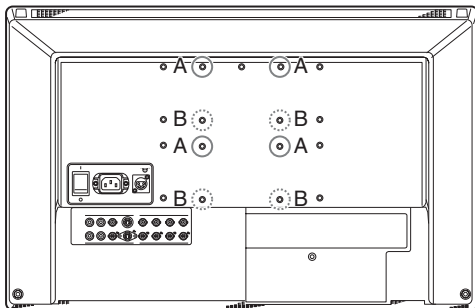

A: Screw holes for low position
B: Screw holes for high position

- 3 Attach the stand attachment bracket with four screws.

Use the screws removed in step 5 of “To remove the stand attachment bracket”.

- 4 Attach the arm.

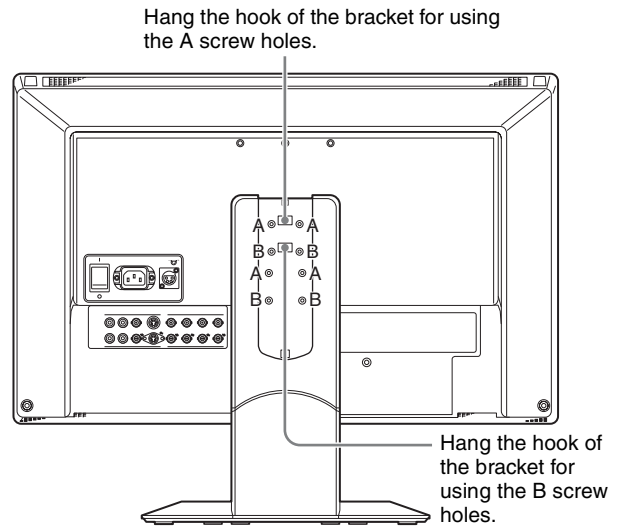

- 5 Secure the arm with four screws.

Use the screws removed in step 3 of “To remove the stand attachment bracket”.

- 6 Attach the arm cover.

To remove the stand attachment bracket

- 1 Put the monitor on a soft cloth with the surface of the LCD monitor downward.
- 2 Slide and remove the arm cover of the stand.
- 3 Remove four screws.
- 4 Remove the arm.
- 5 Remove four screws to remove the stand attachment bracket.

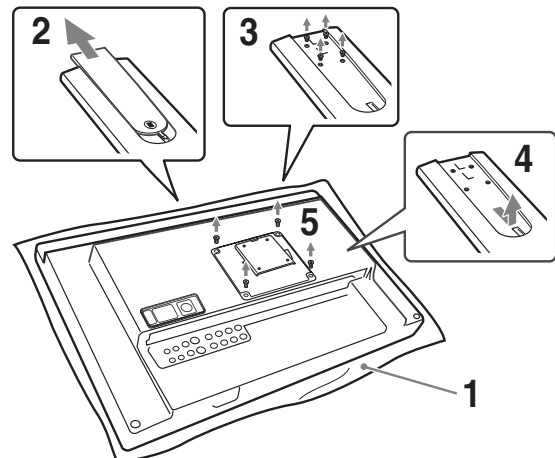

Connecting the AC Power Cord

- 1 Plug the AC power cord into the AC IN socket on the rear panel. Then, attach the AC plug holder (supplied) to the AC power cord.

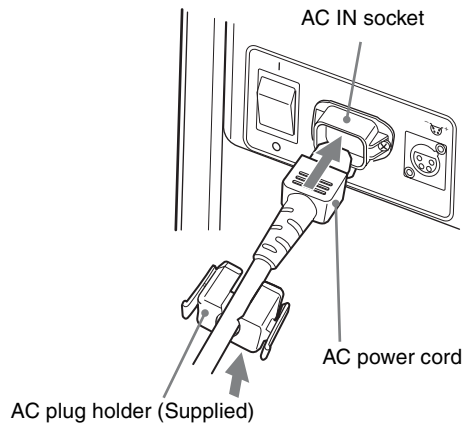

- 2 Slide the AC plug holder over the cord until it locks.

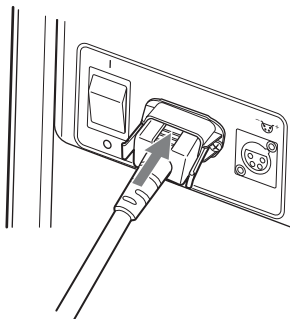

To disconnect the AC power cord

Pull out the AC plug holder while pressing the lock levers.

Installing the Input Adaptor

Before installing the input adaptor, disconnect the power cord.

- 1 Remove the panel of the optional input slot.

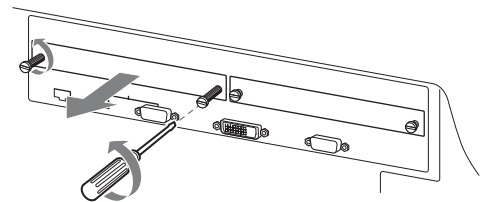

- 2 Insert the input adaptor into the slot.

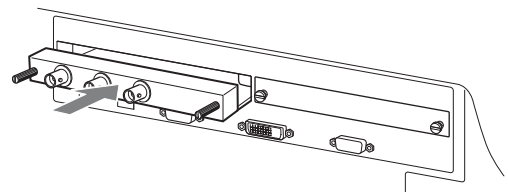

- 3 Tighten the screws.

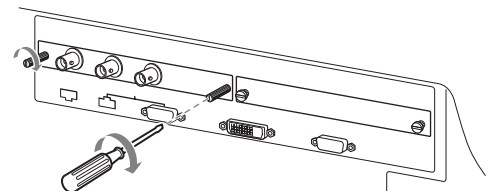

Selecting the Default Settings

When you turn on the unit for the first time after purchasing it, select the area where you intend to use this unit from among the options.

The default setting values for each area

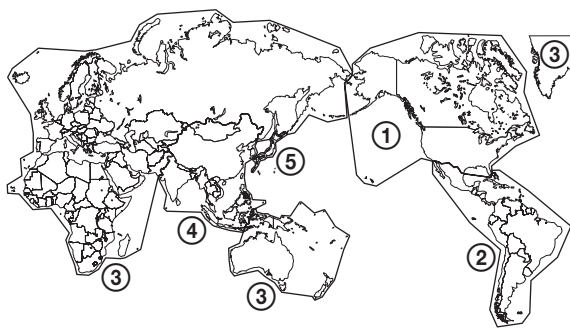

	COLOR TEMP	COMPONENT LEVEL	NTSC SETUP	COLOR SPACE	
① NORTH AMERICA	D65	BETA7.5	7.5	SMPT-C	
② LATIN AMERICA	ARGENTINA	D65	SMPTE	0	EBU
	PARAGUAY	D65	SMPTE	0	EBU
	URUGUAY	D65	SMPTE	0	EBU1
	OTHER AREA	D65	BETA7.5	7.5	SMPT-C
③ AFRICA AUSTRALASIA EUROPE MIDDLE-EAST	D65	SMPTE	0	EBU	
④ ASIA EXCEPT JAPAN	NTSC AREA	D65	BETA7.5	7.5	SMPT-C
	PAL AREA	D65	SMPTE	0	EBU
⑤ JAPAN	D93	SMPTE	0	EBU	

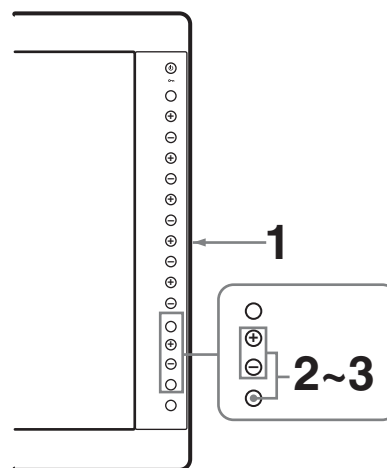

- 1 Turn on the unit with the O/I (power) switch on the rear panel.

The SELECT SETTING screen appears.

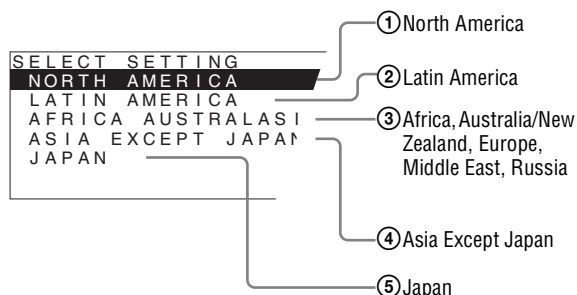

- 2 Press the + or – button to select the area where you intend to use the unit and press the ENTER button.

If you select either ①, ③ or ⑤

The confirmation screen is displayed. Confirm the selected area. When the setting is wrong, press the RETURN button to return to the previous screen.

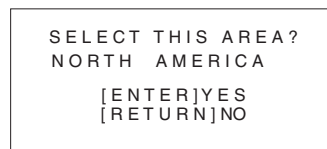

If you select either ② or ④

One of the following screens appears. Press the + or – button to narrow the area further and then press the ENTER button.

The confirmation screen is displayed. Confirm the selected area. When the setting is wrong, press the RETURN button to return to the previous screen.

② If LATIN AMERICA is selected:

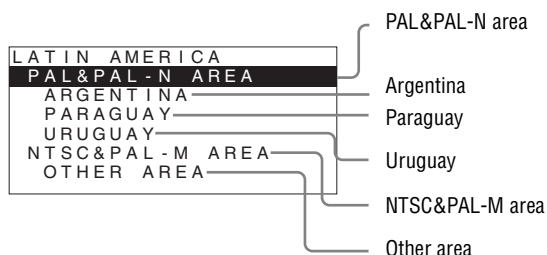

④ If ASIA EXCEPT JAPAN is selected:

Customers who will use this unit in the shaded areas shown in the map below should select NTSC AREA.

Other customers should select PAL AREA.

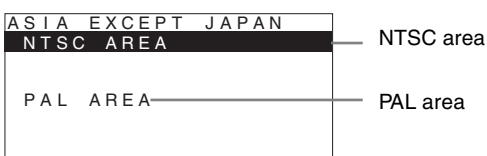

3 Press the ENTER button.

The SELECT SETTING screen disappears and the menu item settings suitable for the selected area are applied.

Note

When you have selected the wrong area, set the following items using the menu. See “The default setting values for each area” (page 15) on the setting value.

- COLOR TEMP (on page 21)
- COMPONENT LEVEL (on page 23)
- NTSC SETUP (on page 23)
- COLOR SPACE (on page 21)

Selecting the Menu Language

You can select one of seven languages (English, French, German, Spanish, Italian, Japanese, Chinese) for displaying the menu and other on-screen displays. “ENGLISH (English)” is selected in the default setting. The current settings are displayed in place of the ■ marks on the illustrations of the menu screen.

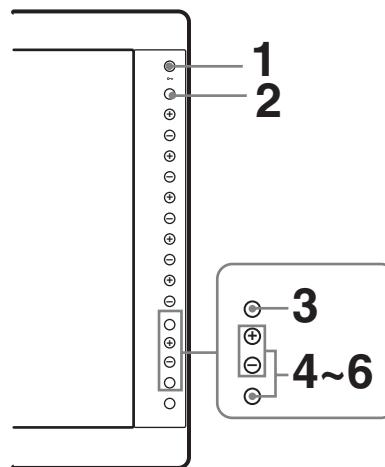

1 Turn on the unit.

2 Press the CONTROL button.

The operation buttons are displayed.

3 Press the MENU button.

The menu appears.

The menu presently selected is shown in yellow.

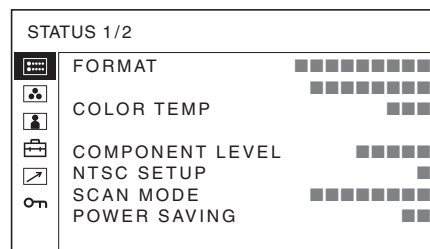

4 Press the + or – button to select SYSTEM SETTING of the USER CONFIG (User Configuration) menu, then press the ENTER button.

The setting items (icons) in the selected menu are displayed in yellow.

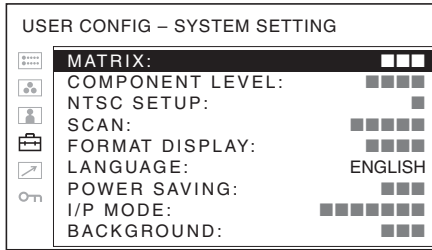

- 5** Press the + or – button to select “LANGUAGE,” then press the ENTER button.

The selected item is displayed in yellow.

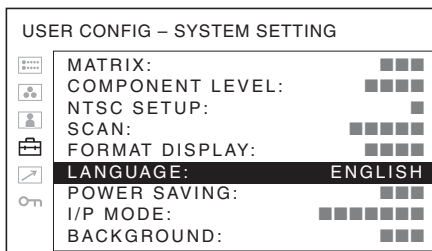

- 6** Press the + or – button to select a language, then press the ENTER button.

The menu changes to the selected language.

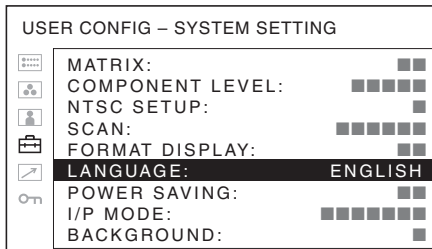

To clear the menu

Press the MENU button.

The menu disappears automatically if a button is not pressed for one minute.

Using the Menu

The unit is equipped with an on-screen menu for making various adjustments and settings such as picture control, input setting, set setting change, etc. You can also change the menu language displayed in the on-screen menu.

To change the menu language, see “Selecting the Menu Language” on page 16.

The current settings are displayed in place of the ■ marks on the illustrations of the menu screen.

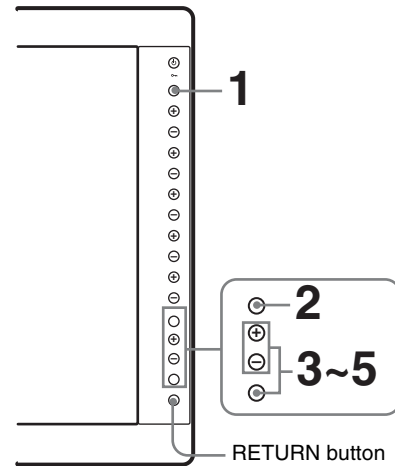

- 1** Press the CONTROL button.

The operation buttons are displayed.

- 2** Press the MENU button.

The menu appears.

The menu presently selected is shown in yellow button.

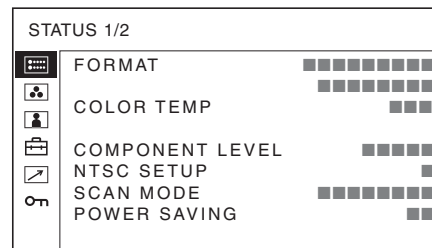

- 3** Use the + or – button to select a menu, then press the ENTER button.

The menu icon presently selected is shown in yellow and setting items are displayed.

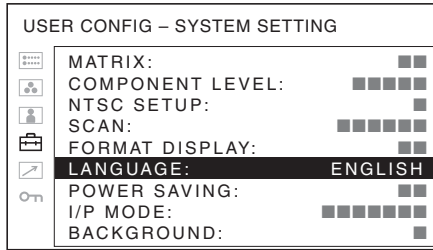

About the memory of the settings

The settings are automatically stored in the monitor memory.

4 Select an item.

Use the + or – button to select the item, then press the ENTER button.

The item to be changed is displayed in yellow.

If the menu consists of multiple pages, press + or – button to go to the desired menu page.

5 Make the setting or adjustment on an item.

When changing the adjustment level:

To increase the number, press the + button.

To decrease the number, press the – button.

Press the ENTER button to confirm the number, then restore the original screen.

When changing the setting:

Press the + or – button to change the setting.

Press the ENTER button to confirm the setting.

When returning the adjustment or setting to the previous value:

Press the RETURN button before pressing the ENTER button.

Notes

- An item displayed in black cannot be accessed. You can access the item if it is displayed in white.
- If the key inhibit has been turned on, all items are displayed in black. To change any of the items, turn the key inhibit to OFF first.

For details on the key inhibit, see page 30.

To return the display to the previous screen

Press the RETURN button.

To clear the menu

Press the MENU button.

The menu disappears automatically if a button is not pressed for one minute.

Adjustment Using the Menus

Items

The screen menu of this monitor consists of the following items.

STATUS (the items indicate the current settings.)

For the video input

FORMAT
COLOR TEMP
COMPONENT LEVEL
NTSC SETUP
SCAN MODE
POWER SAVING
Model name and serial number
OPTION A and serial number
OPTION B and serial number

For the DVI/HD15 input

FORMAT
fH
fV
COLOR TEMP
POWER SAVING
Model name and serial number
OPTION A and serial number
OPTION B and serial number

COLOR TEMP/SPACE

COLOR TEMP
MANUAL ADJUSTMENT
COLOR SPACE

USER CONTROL

For the video input

AUTO CHROMA/PHASE
SUB CONTROL
PICTURE CONTROL
INPUT SETTING

For the DVI/HD15 input

SUB CONTROL
PICTURE CONTROL

USER CONFIG

SYSTEM SETTING

MATRIX
COMPONENT LEVEL
NTSC SETUP
SCAN
FORMAT DISPLAY
LANGUAGE
POWER SAVING
I/P MODE
BACKGROUND
MARKER SETTING
MARKER ENABLE
MARKER SELECT
CENTER MARKER
SAFETY AREA
MARKER LEVEL
MARKER MAT
MULTI DISPLAY SETTING
MULTI DISPLAY ENABLE
MULTI DISPLAY
SUB INPUT SELECT
POSITION
FRAME
SUB PICTURE SIZE
FUNCTION BUTTON SETTING
F1 BUTTON
F2 BUTTON
F3 BUTTON
F4 BUTTON
CLOSED CAPTION SETTING
For the composite or Y/C input
CLOSED CAPTION ENABLE
CAPTION VISION
For a signal input from a BKM-244CC
(when a BKM-244CC is installed)
CLOSED CAPTION ENABLE
CAPTION VISION
BKM-244CC
AUDIO SETTING
INPUT SELECT
OPTION AUDIO SETTING
OPTION SETTING *1
ALM (audio level meter) DISPLAY
POSITION
TRANSPARENCY
T/C DISPLAY
FORMAT
POSITION

*1 Displayed only when a BKM-250TG is installed.

REMOTE

PARALLEL REMOTE
SERIAL REMOTE

KEY INHIBIT

KEY INHIBIT

Adjusting and Changing the Settings

STATUS menu

The STATUS menu is used to display the current status of the unit. The following items are displayed:

For the video input

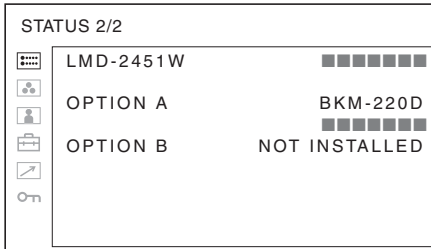
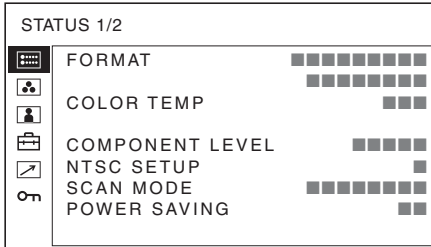

- Signal format
- Color temperature
- Component level
- NTSC setup
- Scan mode
- Power saving
- Model name and serial number
- OPTION A and serial number
- OPTION B and serial number

For the DVI/HD15 input

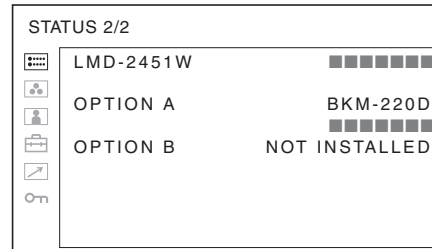
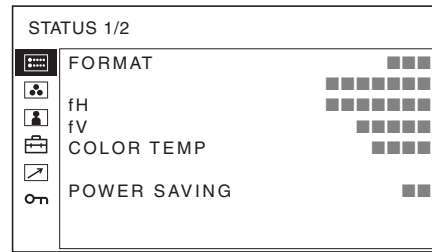

- Signal format
- fH
- fV
- Color temperature
- Power saving
- Model name and serial number
- OPTION A and serial number
- OPTION B and serial number

COLOR TEMP/SPACE menu

The COLOR TEMP/SPACE menu is used for adjusting the picture white balance or color space.

You need to use the measurement instrument to adjust the white balance.

Recommended: Konica Minolta color analyzer CA-210

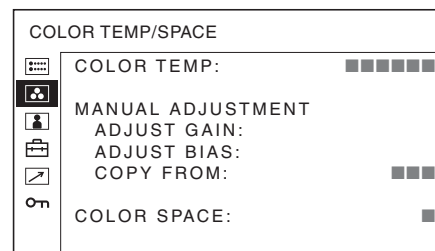

Submenu	Setting
COLOR TEMP	Selects the color temperature from among D65, D93 and USER settings.
MANUAL ADJUSTMENT	<p>If you set the COLOR TEMP to USER setting, the item displayed is changed from black to white, which means you can adjust the color temperature.</p> <p>The set values are memorized.</p> <ul style="list-style-type: none"> • ADJUST GAIN: Adjusts the color balance (GAIN). • ADJUST BIAS: Adjusts the color balance (BIAS). • COPY FROM: If you select D65 or D93, the white balance data for the selected color temperature will be copied in the USER setting.
COLOR SPACE	Selects the color space from among EBU, SMPTE-C, ITU-709 and OFF. OFF sets the color space to the original color reproduction of the LCD panel.

USER CONTROL menu

The USER CONTROL menu is used for adjusting the picture.

Items that cannot be adjusted depending on the input signal are displayed in black.

For the video input

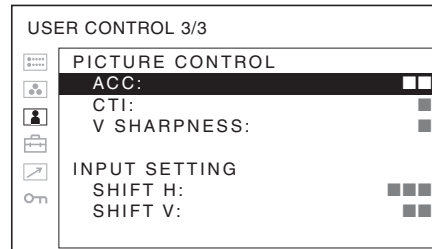
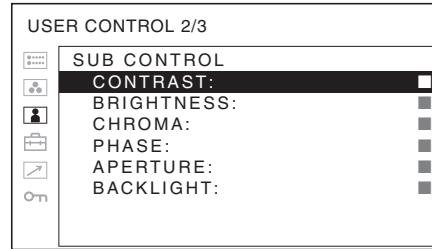
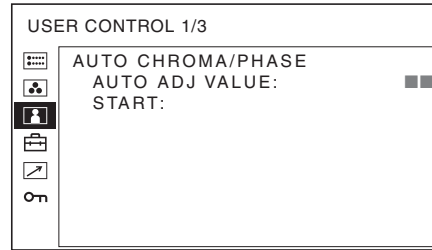

Submenu	Setting
AUTO CHROMA/PHASE	<p>Adjusts color intensity (CHROMA) and tones (PHASE).</p> <ul style="list-style-type: none"> • AUTO ADJ VALUE: Selects ON or OFF of the auto adjustment. When you set to OFF, this parameter is reset to the factory setting. When you set to ON, the automatically adjusted value is enabled. • START: The auto adjustment starts when you display the color bar signals (Full/SMPTE/EIA) on the screen and press the ENTER button. After adjusting the color intensity, press the MENU button to clear the adjustment screen. After the adjustment is done correctly, the AUTO ADJ VALUE is automatically set to ON.

Submenu	Setting
SUB CONTROL	<p>Adjusts finely the adjustment range of the button on the front panel for CONTRAST, BRIGHTNESS, CHROMA and PHASE.</p> <ul style="list-style-type: none"> • CONTRAST: Adjusts the picture contrast. • BRIGHTNESS: Adjusts the picture brightness. • CHROMA: Adjusts color intensity. The higher the setting, the greater the intensity. The lower the setting, the lower the intensity. • PHASE: Adjusts color tones. The higher the setting, the more greenish the picture. The lower the setting, the more purplish the picture. • APERTURE: Adjusts the picture sharpness. The higher the setting, the sharper the picture. The lower the setting, the softer the picture. • BACKLIGHT: Adjusts the backlight. When the setting is changed, the brightness of the backlight is changed. <p>For details of input signals and adjustable/setting items, see page 10.</p>
PICTURE CONTROL	<p>Adjusts the picture.</p> <ul style="list-style-type: none"> • ACC (Auto Color Control): Sets ACC circuit on or off. To check the fine adjustment, select OFF. Normally select ON. • CTI (Chroma Transient Improvement): When a low color resolution signal is input, a crisp image can be displayed. When the setting is higher, the picture becomes even more crisp. • V SHARPNESS: A crisp image can be displayed. When the setting is higher, the picture becomes even more crisp.
INPUT SETTING	<ul style="list-style-type: none"> • SHIFT H: Adjusts the position of the picture. As the setting increases, the picture moves to the right, and as the setting decreases, the picture moves to the left. • SHIFT V: Adjusts the position of the picture. As the setting increases, the picture moves up, and as the setting decreases, the picture moves down.

For the DVI/HD15 input

* The 1/3 menu cannot be adjusted.

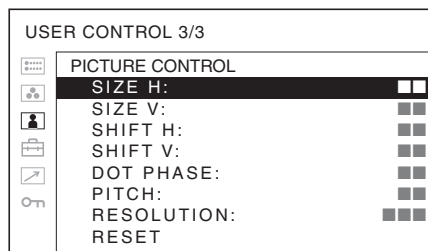
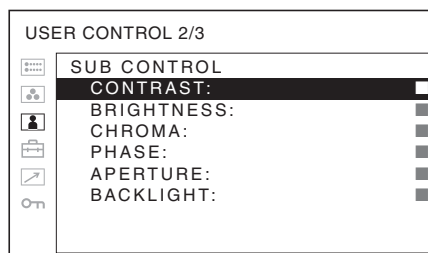

Submenu	Setting
SUB CONTROL	<p>Adjusts finely the adjustment range of the button on the front panel for CONTRAST, BRIGHTNESS, CHROMA and PHASE.</p> <ul style="list-style-type: none"> • CONTRAST: Adjusts the picture contrast. • BRIGHTNESS: Adjusts the picture brightness. • CHROMA: Adjusts color intensity. The higher the setting, the greater the intensity. The lower the setting, the lower the intensity. • PHASE: Adjusts color tones. The higher the setting, the more greenish the picture. The lower the setting, the more purplish the picture. • APERTURE: Adjusts the picture sharpness. The higher the setting, the sharper the picture. The lower the setting, the softer the picture. • BACKLIGHT: Adjusts the backlight. When the setting is changed, the brightness of the backlight is changed. <p>For details of input signals and adjustable/setting items, see page 10.</p>

Submenu	Setting
PICTURE CONTROL	<p>Adjusts to monitor the picture more clearly.</p> <ul style="list-style-type: none"> • SIZE H: Adjusts the horizontal size of the picture. The higher the setting, the larger the horizontal size of the picture. The lower the setting, the smaller the horizontal size of the picture. • SIZE V: Adjusts the vertical size of the picture. The higher the setting, the larger the vertical size of the picture. The lower the setting, the smaller the vertical size of the picture. • SHIFT H: Adjusts the position of the picture. As the setting increases, the picture moves to the right, and as the setting decreases, the picture moves to the left. • SHIFT V: Adjusts the position of the picture. As the setting increases, the picture moves up, and as the setting decreases, the picture moves down. • DOT PHASE: Adjusts the dot phase. Adjust the picture further for a finer picture after APA (page 27) is adjusted. • PITCH: Adjusts the horizontal size of the picture with the left side of the picture fixed. The higher the setting, the larger the width of the picture. The lower the setting, the narrower the width of the picture. • RESOLUTION: Sets when the computer signal is input and it is difficult to understand the signal type such as XGA/60, WXGA/60, UXGA/60 or WUXGA/60. <ul style="list-style-type: none"> • XGA: Displayed as XGA signal. • WXGA: Displayed as WXGA signal. • UXGA: Displayed as UXGA signal. • WUXGA: Displayed as WUXGA signal. • RESET: Resets the value of SIZE H, SIZE V, SHIFT H, SHIFT V, DOT PHASE and PITCH to the factory preset value.

USER CONFIG menu

The USER CONFIG menu is used for setting the system, marker, multi display, function button, closed caption, audio and option.

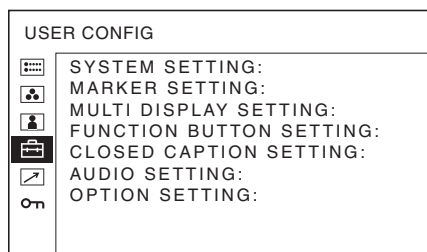

SYSTEM SETTING

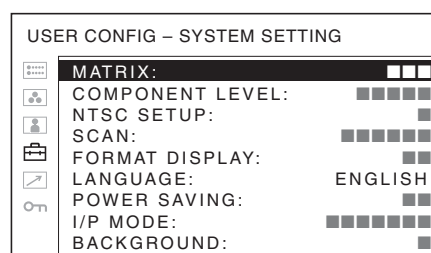

Submenu	Setting
MATRIX	Applied to 480/60I or 480/60P signal. Select 601 or 709.
COMPONENT LEVEL	<p>Selects the component level from among three modes.</p> <ul style="list-style-type: none"> • SMPTE: for 100/0/100/0 signal • BETA0: for 100/0/75/0 signal • BETA7.5: for 100/7.5/75/7.5 signal
NTSC SETUP	<p>Selects the NTSC setup level from two modes.</p> <p>The 7.5 setup level is used mainly in North America. The 0 setup level is used mainly in Japan.</p>
SCAN	<p>Enables setting of the scan mode by the button which the scan function is assigned. Select from among "STANDARD" and "FULL+NATIVE". The displayed picture differs according to the selected mode (see "Scan mode image" on page 24).</p> <p>When STANDARD is selected NORMAL scan (0% scan) and OVER scan (5% over scan)</p> <p>When FULL+NATIVE is selected NORMAL scan, OVER scan, FULL screen and NATIVE (1080i and 720P only)</p>

Submenu	Setting
FORMAT DISPLAY	<p>Selects the display mode of the signal format and scan mode.</p> <ul style="list-style-type: none"> • ON: The format and scan mode are always displayed. • OFF: The display is hidden. • AUTO: The format and scan mode are displayed for about 10 seconds when the input of the signal starts.
LANGUAGE	<p>Selects the menu or message language from among seven languages.</p> <ul style="list-style-type: none"> • ENGLISH: English • FRANÇAIS: French • DEUTSCH: German • ESPAÑOL: Spanish • ITALIANO: Italian • 日本語 : Japanese • 中文 : Chinese
POWER SAVING	<p>Sets the power saving mode on or off. When you set to ON, the monitor goes into power saving mode if no signal is input for about one minute.</p>
I/P MODE (picture delay minimum)	<p>Selects to set the delay by the picture processing to the minimum level when the interlace signal is input.</p> <ul style="list-style-type: none"> • INTER-FIELD: Mode for giving precedence to the picture quality. Performs interpolation depending on the movement of the images between the fields. It takes longer than “FIELD MERGE” or “LINE DOUBLER” for processing the picture. “INTER-FIELD” is the factory setting. • FIELD MERGE: The processing time is shorter. Combines the lines in the odd fields and even fields alternately regardless of the movement of images. Suitable for viewing still images. • LINE DOUBLER: The processing time is shorter. Performs interpolation by repeating each line in the data receiving sequence regardless of the field. As the line flicker is displayed in this mode, it is available for checking the line flicker of the telop work and so on.

Submenu	Setting
BACKGROUND	<p>Sets the brightness of the black bars appearing in the upper and lower positions of the screen, or on the sides of the screen.</p> <ul style="list-style-type: none"> • OFF: Displays a darker bar (black). • ON: Displays a brighter bar (gray).

Scan mode image

INPUT	
NORMAL (zeroscan)	<p>4:3</p> <p>1600 × 1200 1920 × 1080</p>
OVER (5% over scan)	<p>1680 × 1200 1920 × 1134</p>
FULL	<p>—</p> <p>1920 × 1200</p>
NATIVE (1080i)	<p>—</p> <p>1920 × 1080</p>
NATIVE (720P)	<p>—</p> <p>1280 × 720</p>

MARKER SETTING

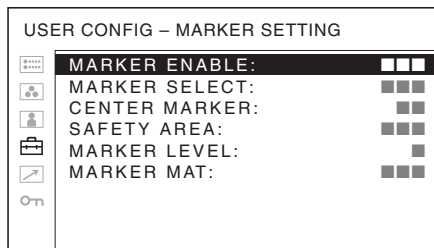

Submenu	Setting
MARKER ENABLE	Selects ON to display the marker and OFF not to display.
Note	
When NATIVE is selected in the SCAN setting, the marker is not displayed. To display the marker, select a setting other than NATIVE.	
MARKER SELECT	Selects the aspect ratio according to the film, when the frame of the film is displayed on the screen. When 16:9 aspect ratio is selected with the button which the aspect function is assigned You can select from among 4:3, 15:9, 14:9, 13:9, 1.85:1, 2.35:1, 1.85:1 & 4:3 and OFF. When 4:3 aspect ratio is selected with the button which the aspect function is assigned You can select 16:9 or OFF.
CENTER MARKER	Selects ON to display the center mark of the picture and OFF not to display.
SAFETY AREA	Selects the safe area size for the aspect ratio determined by the button which the aspect function is assigned. You can select from among OFF, 80%, 85%, 88%, 90% and 93%. When the marker is displayed, the safe area for the marker is displayed.
MARKER LEVEL	Sets the luminance to display the MARKER SELECT, CENTER MARKER and SAFETY AREA. You can select from among 1 to 3. When the setting is low, the marker is displayed dark.
MARKER MAT	Selects whether you put mat on the outside of the marker display. <ul style="list-style-type: none"> • OFF: No mat is put. • HALF: Gray mat is put. • BLACK: Black mat is put.

MULTI DISPLAY SETTING

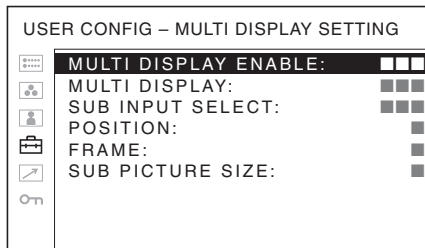

Submenu	Setting
MULTI DISPLAY ENABLE	Selects ON to display the multi display and OFF not to display.
Notes	
<ul style="list-style-type: none"> • When the frame frequency of the main display is different from that of the sub display, the picture may be disturbed. When no signal is input to the main display, the picture may not be displayed correctly. • When the multi display is enabled, the marker display is not available. 	
MULTI DISPLAY	<ul style="list-style-type: none"> • PIP/POP: The sub display is put in the main display for the 16:9 display and by the side of the main display for the 4:3 display. • SIDE BY SIDE: The main display is put in the left side of the display and the sub display is put in the right side of the display.
Notes	
<ul style="list-style-type: none"> • When the HD15 signal is input to the main display, SIDE BY SIDE cannot be selected on the menu. • When MULTI DISPLAY is set to SIDE BY SIDE, CTI (page 22) is not available. 	

Submenu	Setting
SUB INPUT SELECT	<p>Sets the input signal of the sub display. You can select from among COMPOSITE, Y/C, RGB, COMPONENT, OPTION A-1, OPTION A-2, OPTION B-1, OPTION B-2, VIDEO WAVE and OFF.</p> <p>When you select VIDEO WAVE, the waveform and audio level are displayed. (Audio level is displayed only when you connect the BKM-220D/243HS/244CC/250TG.)</p> <p>The indications of the waveform and audio level signify as illustrated below, although the percentage of the waveform, audio level L/R CH, units and values of the scale do not appear on the display.</p>

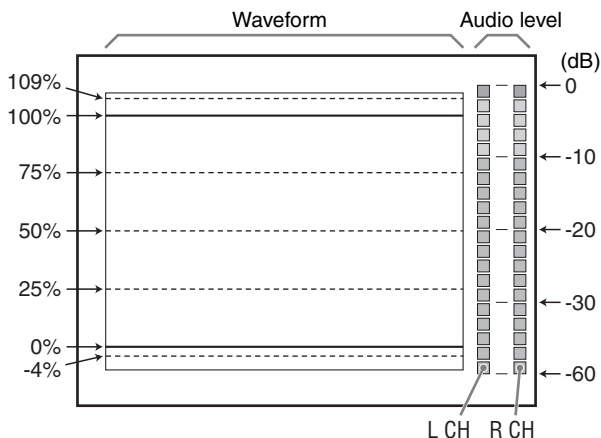

Notes

- The multi display with COMPOSITE and Y/C, RGB and COMPONENT, OPTION A-1 and OPTION A-2, and OPTION B-1 and OPTION B-2 is not displayed.
- When SUB INPUT SELECT is set to OFF, the sub display is not displayed even if you set MULTI DISPLAY ENABLE to ON.

POSITION	<p>Sets the position of the sub display. You can select from among 1 to 3 for the 4:3 display and 1 to 4 for the 16:9 display.</p> <p>4:3 display</p> <ul style="list-style-type: none"> • 1: Top • 2: Center • 3: Bottom <p>16:9 display</p> <ul style="list-style-type: none"> • 1: Bottom left • 2: Bottom right • 3: Top right • 4: Top left
FRAME	<p>Sets the position of the main display when MULTI DISPLAY is set to POP and the sub display is put on the 4:3 display.</p> <ul style="list-style-type: none"> • RIGHT: The main display is put by the right side of the sub display. • LEFT: The main display is put by the left side of the sub display.

Submenu	Setting
SUB PICTURE SIZE	<p>Sets the size of the sub picture. You can select from among 1 to 3. When the setting is high, the size becomes large.</p>

FUNCTION BUTTON SETTING

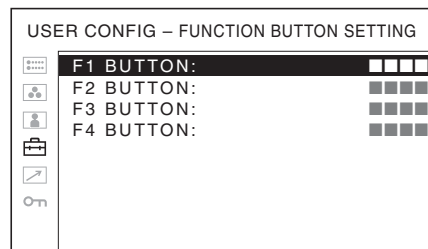

Submenu	Setting
F1 BUTTON to F4 BUTTON	<p>Assigns the function to the function buttons of the front panel and turns the function on or off.</p> <p>You can assign the function from among SCAN, ASPECT, EXT SYNC, BLUE ONLY, MONO, MARKER, H/V DELAY, MULTI DISPLAY, CLOSED CAPTION, APA and I/P MODE.</p> <p>Factory setting</p> <ul style="list-style-type: none"> • F1 button: EXT SYNC • F2 button: SCAN • F3 button: ASPECT • F4 button: H/V DELAY

About the function assigned to the function button

SCAN

Press the button to change the scan size of the picture according to the setting of “STANDARD” or “FULL+NATIVE” selected in SCAN (page 23).

ASPECT

Press the button to set the aspect ratio of the picture, 4:3 or 16:9.

Note

The panel of the monitor is 16:10. When the 16:9 signal is displayed, black bars appear in the upper and lower positions of the display. This is not a malfunction. (See “Scan mode image” on page 24.)

EXT SYNC (external sync)

Press the button to operate the unit on an external sync signal through the EXT SYNC IN connector. EXT SYNC works when the component/RGB signals are input.

BLUE ONLY

Press the button to eliminate the red and green signals. Only blue signal is displayed as an apparent monochrome picture on the screen. This facilitates “chroma” and “phase” adjustments and observation of VCR noise.

MONO

Press the button to display a monochrome picture. When the buttons is pressed again, the monitor switches automatically to color mode.

MARKER

Press the button to display the marker. Set the aspect marker and safety area size in the MARKER SETTING menu (see page 25).

H/V DELAY

Press the button to observe the horizontal and vertical sync signals at the same time.

MULTI DISPLAY

Press the button to display the multi display. Set the multi display setting in the MULTI DISPLAY SETTING menu (see page 25).

CLOSED CAPTION

Press the button to display the closed caption. Set the closed caption setting in the CLOSED CAPTION SETTING menu (see page 27).

APA (Auto Pixel Alignment)

Press the button to adjust the picture automatically to maximum clarity for the signal input to the HD15 input connector. For finer according to the input signal, see “DOT PHASE” on page 23.

When the menu screen is displayed, the APA does not function.

Note

If the APA operation does not finish correctly depending on the input signal, adjust DOT PHASE (page 23).

I/P MODE

Press the button to set the delay by the picture processing to the minimum level when interlace signal is input. The mode switches in the sequence INTER-FIELD → FIELD MERGE → LINE DOUBLER with every press of the button (see “I/P MODE” on page 24).

CLOSED CAPTION SETTING

For the composite or Y/C input

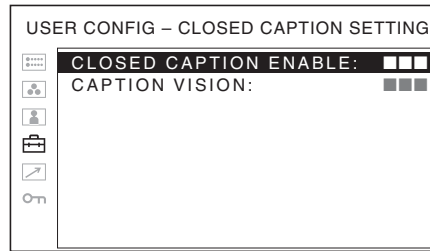

Submenu	Setting
CLOSED CAPTION ENABLE	Select ON to display closed caption and OFF not to display.
Note	
When you display closed caption, set FORMAT DISPLAY (page 24) to OFF or AUTO, and set MARKER ENABLE (page 25) to OFF.	
CAPTION VISION	Sets closed caption. You can select from among OFF, CC1, CC2, CC3, CC4, TEXT1 and TEXT2.

For a signal input from a BKM-244CC (when a BKM-244CC is installed)

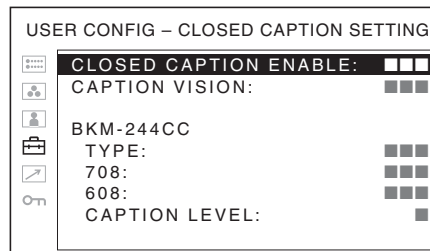

Submenu	Setting
CLOSED CAPTION ENABLE	Select ON to display closed caption and OFF not to display.
CAPTION VISION	Sets closed caption. You can select from among OFF, CC1, CC2, CC3, CC4, TEXT1 and TEXT2.

Submenu	Setting
BKM-244CC	<p>Sets closed caption.</p> <ul style="list-style-type: none"> • TYPE: Selects the closed caption signal format. <ul style="list-style-type: none"> • 708: To display a closed caption signal conforming to the EIA/CEA-708 standard. • 608 (708): To display a closed caption signal conforming to the EIA/CEA-608 standard transmitted as EIA/CEA-708 data. • 608 (ANC): To display a closed caption signal conforming to the EIA/CEA-608 standard transmitted as ANC (ancillary) data. • 608 (VBI): To display a closed caption signal conforming to the EIA/CEA-608 standard transmitted over Line 21. • 708: This item is displayed when TYPE is set to “708”, and you can set closed caption. Select from among 1 to 6. • 608: This item is displayed when TYPE is set to “608 (708)”, “608 (ANC)” or “608 (VBI)”, and you can set closed caption. Select from among CC1, CC2, CC3, CC4, TEXT1, TEXT2, TEXT3 and TEXT4. • CAPTION LEVEL: Sets the luminance of the displayed characters. You can select from among 1, 2 and 3.

Note

When two BKM-244CC adaptors are installed, the last set information is applied to both adaptors.

AUDIO SETTING

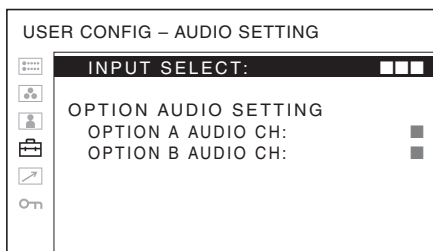

Submenu	Setting
INPUT SELECT	<p>Selects the input audio signal.</p> <ul style="list-style-type: none"> • ALL: The sound except from BKM-220D/243HS/244CC/250TG is output. • COMPOSITE: When the COMPOSITE button is pressed, the sound is output. • Y/C: When the Y/C button is pressed, the sound is output. • RGB: When the RGB button is pressed, the sound is output. • COMPONENT: When the COMPONENT button is pressed, the sound is output. • HD15: When the HD15 button is pressed, the sound is output. • DVI: When the DVI button is pressed, the sound is output.
OPTION AUDIO SETTING	<p>When BKM-220D/243HS/244CC/250TG is installed, set the audio channel for each adaptor. CH1, CH2, CH1+CH2, CH3, CH4, CH3+CH4, CH5, CH6, CH5+CH6, CH7, CH8, CH7+CH8, CH9, CH10, CH9+CH10, CH11, CH12, CH11+CH12, CH13, CH14, CH13+CH14, CH15, CH16, CH15+CH16, OFF</p> <p>You can display the L/R audio levels of the selected channels on the display when the multi display is enabled.</p>

OPTION SETTING

* This setting is displayed only when a BKM-250TG is installed.

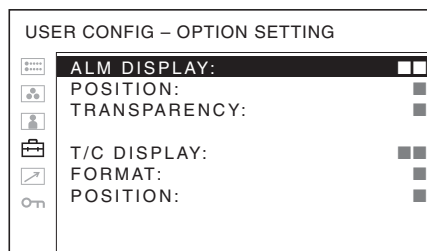

Submenu	Setting
ALM DISPLAY	Selects ON to display the ALM (audio level meter) display and OFF not to display. The indications of the audio level signify as illustrated below, although the units and values of the scale do not appear on the display.

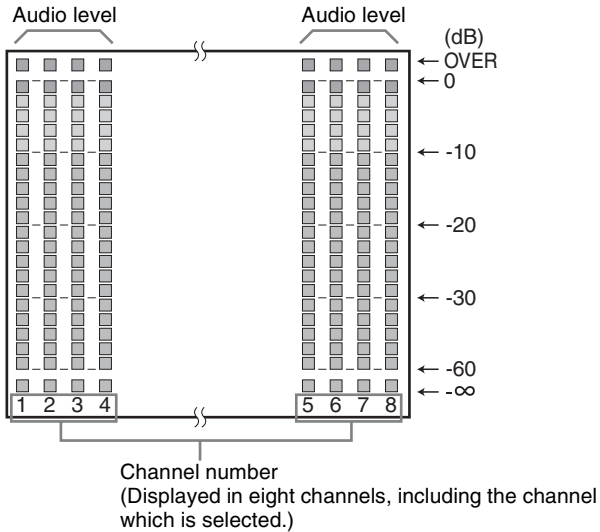

POSITION	<p>Sets the position of the ALM display. You can select between 1 and 2.</p> <ul style="list-style-type: none"> • 1: Top • 2: Bottom
TRANSPARENCY	<p>Selects from 1 and 2 for the background of the ALM display.</p> <ul style="list-style-type: none"> • 1: The background is black. Displayed image is hidden behind the background. • 2: The background is transparent. Displayed image can be seen indistinctly behind the ALM display.
T/C DISPLAY	Selects ON to display the time code display and OFF not to display.
FORMAT	<p>Sets the time code format.</p> <ul style="list-style-type: none"> • VITC: To display the time code in VITC format. • LTC: To display the time code in LTC format.
POSITION	<p>Sets the position of the time code display. You can select between 1 and 2.</p> <ul style="list-style-type: none"> • 1: Bottom • 2: Top

REMOTE menu

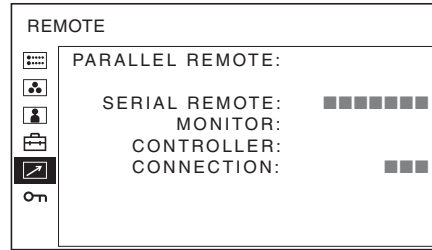

Submenu	Setting
PARALLEL REMOTE	<p>Selects the PARALLEL REMOTE connector pins for which you want to change the function. You can assign various functions to 1 to 4 pins and 6 to 8 pins. The following lists the functions you can assign to the pins.</p> <ul style="list-style-type: none"> ---- (“----”: No function is assigned.) COMPOSITE Y/C RGB COMPONENT DVI HD15 OPTION A-1 OPTION A-2 OPTION B-1 OPTION B-2 OVERSCAN FULL NORMAL NATIVE 4:3 16:9 TALLY R TALLY G EXT SYNC BLUE ONLY MONO H/V DELAY 16:9 MARKER 15:9 MARKER 14:9 MARKER 13:9 MARKER 1.85:1 MARKER 2.35:1 MARKER 1.85:1 & 4:3 MARKER 4:3 MARKER CENTER MARKER SAFE AREA 80% SAFE AREA 85% SAFE AREA 88% SAFE AREA 90% SAFE AREA 93% MARKER MAT HALF MARKER MAT BLACK

Notes

- If you use the PARALLEL REMOTE function, you need to connect cables. For more details, see page 33.
- Set MARKER ENABLE (page 25) to ON to control the aspect marker, center marker or safe area marker.

Submenu	Setting
SERIAL REMOTE	<p>Selects the mode to be used.</p> <ul style="list-style-type: none"> • OFF: SERIAL REMOTE does not function. • RS-232C: The monitor is controlled by the command of RS-232C. • ETHERNET: The monitor is controlled by the command of Ethernet. • BKM-15R: Sets BKM-15R.
MONITOR	<p>Sets the monitor setting.</p> <p>MONITOR ID: Sets the ID of the monitor.</p> <p>GROUP ID: Sets the group ID of the monitor.</p> <p>IP ADDRESS: Sets the IP address.</p> <p>SUBNET MASK: Sets the subnet mask. (255.255.255.000)</p> <p>DEFAULT GATEWAY: Sets the default gateway on or off.</p> <p>ADDRESS: Sets the default gateway.</p> <p>CANCEL: Selects to cancel the setting.</p> <p>CONFIRM: Selects to save the setting.</p>
CONTROLLER	<p>Sets the address of the remote controller.</p> <p>IP ADDRESS: Sets the IP address.</p> <p>SUBNET MASK: Sets the subnet mask. (255.255.255.000)</p> <p>DEFAULT GATEWAY: Sets the default gateway on or off.</p> <p>ADDRESS: Sets the default gateway.</p> <p>CANCEL: Selects to cancel the setting.</p> <p>CONFIRM: Selects to save the setting.</p>
CONNECTION	<p>Sets the connection of the monitor and the controller.</p> <p>PEER TO PEER: for one to one connection</p> <p>LAN: for connection via a network</p>

KEY INHIBIT menu

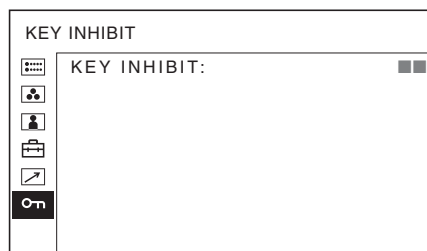

You can lock the setting so that they cannot be changed by an unauthorized user.

Select OFF or ON.

If you set to ON, all items are displayed in black, indicating the items are locked.

Troubleshooting

This section may help you isolate the cause of a problem and as a result, eliminate the need to contact technical support.

- **The display is colored in green or purple** → Select the correct input by pressing RGB or COMPONENT button.
- **The unit cannot be operated** → The key protection function works. Set the KEY INHIBIT setting to OFF in the KEY INHIBIT menu.
- **The black bars appear at the upper and lower positions of the display** → When the signal aspect ratio is different from that of the panel, the black bars appear. This is not a failure of the unit.

Specifications

Picture performance

LCD panel	a-Si TFT Active Matrix
Pixel efficiency	99.99%
Viewing angle (up/down/left/right, contrast > 10:1)	89°/89°/89°/89° (typical)
Scan	Normal 0% Over scan 5%
Efficient picture size	518.4 × 324.0, 613.2 mm (w/h, dia) (20 ¹ / ₂ × 12 ⁷ / ₈ , 24 inches)
Resolution	H 1,920 dots, V 1,200 lines
Aspect ratio	16:10

Input

Composite input (NTSC/PAL) connector	BNC type (1) 1 Vp-p ± 3 dB sync negative
Y/C input connector	4-pin mini-DIN (1) Y: 1 Vp-p ± 3 dB sync negative C: 0.286 Vp-p ± 3 dB (NTSC burst signal level) 0.3 Vp-p ± 3 dB (PAL burst signal level)
RGB/component input connectors	BNC type (3) RGB input: 0.7 Vp-p ± 3 dB (Sync On Green, 0.3 Vp-p sync negative) Component input: 0.7 Vp-p ± 3 dB (75% chrominance standard color bar signal)
Audio input connectors	Phono jack (2) -5 dBu 47 kilohms or higher
External synchronized input connector	BNC type (1) 0.3 to 4.0 V p-p ± bipolarity ternary or negative polarity binary
HD15 input connector	D-sub 15-pin (1) R/G/B: 0.7 Vp-p, sync positive (Sync On Green, 0.3 Vp-p sync negative) Sync: TTL level (polarity free, H/V separate sync) Plug & Play function: corresponds to DDC2B
DVI input connector	DVI-D (1) TMDS single link
Remote input connector	Parallel remote Modular connector 8-pin (1) Serial remote

D-sub 9-pin (RS-232C) (1)
RJ-45 modular connector
(ETHERNET) (1)

Optional input slot

2 slots
Signal format:
H: 15 kHz to 45 kHz
V: 48 Hz to 60 Hz

DC IN connector

DC 24 V (output impedance 0.05 Ω or less)

Output

Composite output connector	BNC type (1) Loop-through, with 75 ohms automatic terminal function
Y/C output connector	4-pin mini-DIN (1) Loop-through, with 75 ohms automatic terminal function
RGB/component connectors	BNC type (3) Loop-through, with 75 ohms automatic terminal function
External synchronized output connector	BNC type (1) Loop-through, with 75 ohms automatic terminal function
Audio monitor output connectors	Phono jack (2)
Built-in speaker output	1.0 W + 1.0 W (stereo)

General

Power	AC 100 V to 240 V, 50/60 Hz, 1.5 A to 0.7 A DC 24 V, 5.7 A
Power consumption	Maximum: approx. 130 W (when two BKM-229X are installed)
Peak inrush current	(1) Power ON, current probe method: 23 A (100 V), 56 A (240 V) (2) Hot switching inrush current, measured in accordance with European standard EN55103-1: 55 A (230 V)
Dimensions	Approx. 602.4 × 497.9 × 269.9 mm (including the projection parts) (23 ³ / ₄ × 19 ⁵ / ₈ × 10 ³ / ₄ inches) (w/h/d)
Mass	Approx. 11.0 kg (24 lb 4 oz) (when no input adaptor is installed) Approx. 11.4 kg (25 lb 2 oz) (when two BKM-229X are installed)
Operating conditions	

Temperature

0 °C to 35 °C (32 °F to 95 °F)

Recommended temperature

20 °C to 30 °C (68 °F to 86 °F)

Humidity 30% to 85% (no condensation)

Pressure 700 hPa to 1060 hPa

Storage and transport conditions

Temperature

-20 °C to + 60 °C (-4 °F to +140 °F)

Humidity 0% to 90%

Pressure 700 hPa to 1060 hPa

Accessories supplied

AC power cord (1)

AC plug holder (1)

Operating Instructions (1)

CD-ROM (1)

Using the CD-ROM Manual (1)

Warranty book (1)

Optional accessories

SDI 4:2:2 input adaptor

BKM-220D

HD/D1-SDI input adaptor

BKM-243HS

NTSC/PAL input adaptor

BKM-227W

Analog component input adaptor

BKM-229X

HD/SD-SDI closed caption adaptor

BKM-244CC

3G/HD/SD-SDI input adaptor

BKM-250TG

Design and specifications are subject to change without notice.

Note

Always verify that the unit is operating properly before use. **SONY WILL NOT BE LIABLE FOR DAMAGES OF ANY KIND INCLUDING, BUT NOT LIMITED TO, COMPENSATION OR REIMBURSEMENT ON ACCOUNT OF THE LOSS OF PRESENT OR PROSPECTIVE PROFITS DUE TO FAILURE OF THIS UNIT, EITHER DURING THE WARRANTY PERIOD OR AFTER EXPIRATION OF THE WARRANTY, OR FOR ANY OTHER REASON WHATSOEVER.**

Pin assignment

PARALLEL REMOTE connector

Modular connector
(8-pin)

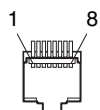

Pin number	Functions
1	Designating composite input signal

Pin number	Functions
2	Designating component input signal
3	Setting tally lamp green ON/OFF
4	Setting tally lamp red ON/OFF
5	GND
6	Selecting external sync
7	Selecting over scan
8	Selecting normal scan

You can allocate functions using the REMOTE menu (see page 29).

Wiring required to use the Remote Control

Connect the function you want to use with a Remote Control to the Ground (Pin 5).

SERIAL REMOTE (RS-232C) connector

D-sub 9 pin, female

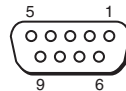

Pin number	Signal
1	NC
2	RX
3	TX
4	NC
5	GND
6	NC
7	RTS
8	CTS
9	NC

Available signal formats

The unit is applicable to the following signal formats.

System	Composite Y/C BKM-227W	RGB Component BKM-229X	BKM-220D	BKM-243HS/ 244CC	BKM-250TG
575/50I (PAL)	○	○	○	○	○
480/60I (NTSC)*1	○	○	○	○	○
576/50P		○			
480/60P		○			
1080/24PsF*1		○*2		○	○
1080/25PsF		○*2		○	○
1080/24P*1		○*2		○	○
1080/25P		○*2		○	○

System	Composite Y/C BKM-227W	RGB Component BKM-229X	BKM-220D	BKM-243HS/ 244CC	BKM-250TG
1080/30P ^{*1}		○ ^{*2}		○	○
1080/50I		○		○	○
1080/60I ^{*1}		○		○	○
720/50P		○ ^{*2}		○	○

System	Composite Y/C BKM-227W	RGB Component BKM-229X	BKM-220D	BKM-243HS/ 244CC	BKM-250TG
720/60P ^{*1}		○		○	○
1080/50P					○
1080/60P					○

*1 The frame rate is also compatible with 1/1.001.

*2 Component only.

Available HD15 input signal formats

VESA DMT

Resolution	Dot clock [MHz]	fH [kHz]	fV [Hz]	Sync. polarity		LMD-2451W
				Horizontal	Vertical	
640 × 480 60 Hz	25.175	31.469	59.940	Negative	Negative	○
800 × 600 56 Hz	36.000	35.156	56.250	Positive	Positive	○
800 × 600 60 Hz	40.000	37.879	60.317	Positive	Positive	○
800 × 600 72 Hz	50.000	48.077	72.188	Positive	Positive	○
800 × 600 75 Hz	49.500	46.875	75.000	Positive	Positive	○
800 × 600 85 Hz	56.250	53.674	85.061	Positive	Positive	○
1024 × 768 60 Hz	65.000	48.363	60.004	Negative	Negative	○
1024 × 768 70 Hz	75.000	56.476	70.069	Negative	Negative	○
1024 × 768 75 Hz	78.750	60.023	75.029	Positive	Positive	○
1024 × 768 85 Hz	94.500	68.677	84.997	Positive	Positive	○
1152 × 864 75 Hz	108.000	67.500	75.000	Positive	Positive	○
1280 × 960 60 Hz	108.000	60.000	60.000	Positive	Positive	○
1280 × 1024 60 Hz	108.000	63.981	60.020	Positive	Positive	○

VESA CVT

Resolution	Dot clock [MHz]	fH [kHz]	fV [Hz]	Sync. polarity		LMD-2451W
				Horizontal	Vertical	
640 × 480 60 Hz	23.625	29.531	59.780	Positive	Negative	○
800 × 600 60 Hz	35.500	36.979	59.837	Positive	Negative	○
1024 × 768 60 Hz	56.000	47.297	59.870	Positive	Negative	○
1280 × 960 60 Hz	85.250	59.201	59.920	Positive	Negative	○
1600 × 1200 50 Hz	132.375	61.742	49.994	Negative	Positive	○
1600 × 1200 60 Hz	130.375	74.077	59.981	Positive	Negative	○
1360 × 768 50 Hz	69.500	39.489	49.922	Negative	Positive	○
1360 × 768 60 Hz	84.625	47.649	59.936	Negative	Positive	○
1360 × 768 60 Hz	72.000	47.368	59.960	Positive	Negative	○
1920 × 1080 50 Hz	141.375	55.572	49.975	Negative	Positive	○
1920 × 1080 60 Hz	138.625	66.647	59.988	Positive	Negative	○

Resolution	Dot clock [MHz]	fH [kHz]	fV [Hz]	Sync. polarity		LMD-2451W
				Horizontal	Vertical	
1280 × 1024 60 Hz	91.000	63.194	59.957	Positive	Negative	○
1280 × 768 50 Hz	65.125	39.518	49.959	Negative	Positive	○
1280 × 768 60 Hz	80.125	47.693	59.992	Negative	Positive	○
1280 × 768 75 Hz	102.875	60.091	74.926	Negative	Positive	○
1280 × 768 60 Hz	68.250	47.396	59.995	Positive	Negative	○

*Down convert display

Others

Resolution	Dot clock [MHz]	fH [kHz]	fV [Hz]	Sync. polarity		LMD-2451W
				Horizontal	Vertical	
720 × 400 70 Hz	28.322	31.469	70.087	Negative	Positive	○
1280 × 800 60 Hz	68.900	48.935	59.969	Negative	Negative	○

Available DVI input signal formats

Range of DVI input signal (available to UXGA/60Hz)

Vertical frequency: 50.0 Hz to 85.1 Hz

Horizontal frequency: 31.5 kHz to 77.0 kHz

Dot clock: 25.175 MHz to 162.000 MHz

Picture size, phase: automatic discrimination by the DE (Data Enable) signal

Dimensions

Front

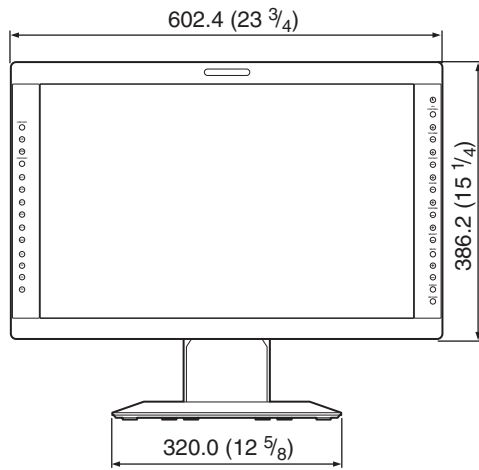

Rear

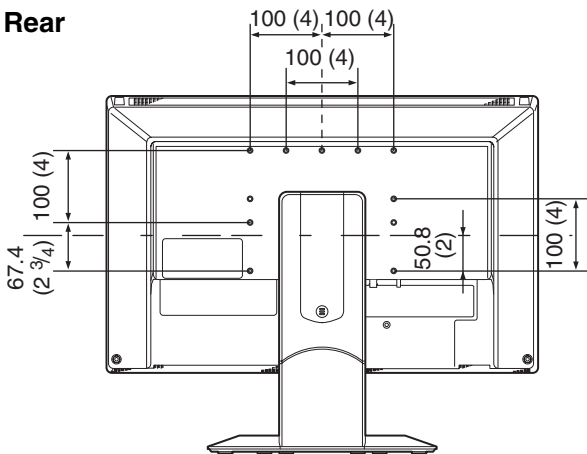

Side

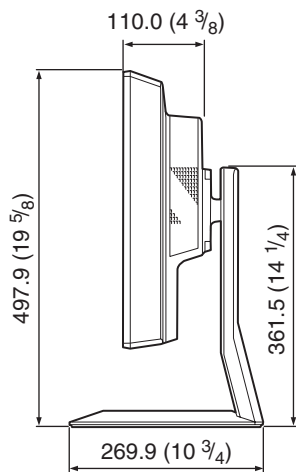

Unit: mm (inches)

